

EDDYSTONE

COMMUNICATIONS RECEIVER TYPE "730/1A"



FREQUENCY COVERAGE

Band 1	...	30	Mc/s.	to	12.3	Mc/s.
Band 2	...	12.5	Mc/s.	to	5.3	Mc/s.
Band 3	...	5.7	Mc/s.	to	2.5	Mc/s.
Band 4	...	2.5	Mc/s.	to	1.11	Mc/s.
Band 5	...	1120	kc/s.	to	480	kc/s.

CIRCUIT AND VALVE SEQUENCE

Two Radio Frequency Stages	6BA6	Output	6AM5/7D9
Frequency-changer	6BE6	Beat Freq. Osc.	6BA6
Separate Oscillator	6AM6/8D3	Noise Limiter	6AL5/D77
Two I. F. Stages	6BA6	Calibrator	6AM6/8D3
Detector and A.G.C.	6AL5/D77	Rectifier	5Z4G
Audio Amplifier	12AU7	Voltage Stabiliser	VR150/30

INSTALLATION AND OPERATION

The receiver has been carefully calibrated, aligned and thoroughly tested and the only adjustment that may be necessary before putting the receiver into operation is to the mains input voltage tapping. The plug in the selector panel on the mains transformer (easily accessible with the lid open) is fitted normally in the 230 volt position, where it should remain when the mains supply voltage is between 220 and 250 volts. If the mains voltage lies between 195 and 215 volts, the plug should be changed to the 200 volt marking. The 110 volt tap applies when the mains supply is between 100 and 120 volts. Unless specially ordered, the transformer is unsuitable for 25 cycle mains. D.C. mains supplies are entirely unsuitable and if connected will cause serious damage to the mains transformer.

A loudspeaker — preferably the Cat. No. 814 — having an impedance of 2.5/3 ohms is connected to the terminals marked "L.S." at the rear or, alternatively, a pair of telephones plugged into the jack on the front panel. The brilliance of the dial lights is adjustable by manipulation of the knob at the rear.

At the rear also are terminals, suitably marked, for feeding the output into a 600 ohm line.

AERIAL CONNECTIONS.

The input impedance at the aerial terminals is nominally 70/80 ohms on Ranges 1, 2 and 3 and 400 ohms on Ranges 4 and 5. Two coaxial sockets, connected in parallel, are fitted at the rear to take the feeder coming in from the aerial system.

RECEPTION OF CW TELEGRAPHY.

The panel controls should be set as follows:-

AGC	"off."
BFO	"on."
Crystal Phasing Knob		White spot at "off."
BFO Pitch Control	..	Spot slightly to one side of centre.
RF Gain	Adjust as necessary.
AF Gain	Adjust as necessary.
Selectivity	Maximum or intermediate.

The settings of the controls depend on a number of factors including the strength of the incoming signals, amount of interference present and the efficiency of the aerial. If the latter is poor, it will be advisable to use maximum RF gain, but often the RF gain can be reduced with advantage. It should always be reduced when signals are strong.

The BFO on/off switch forms part of the pitch control capacitor. The latter permits a swing of about 3,000 cycles each side of zero beat and will normally be set to give a pitch of 1,000 c.p.s. or near. Careful handling of this control will sometimes enable a desired signal to be separated from an interfering signal and one side of zero beat may be better than the other side.

USE OF CRYSTAL FILTER.

It is advantageous to employ a high degree of selectivity because the noise output from the receiver is partly dependent on the IF bandwidth and the narrower this is made, the less the noise for the same amount of gain. It will therefore generally be desirable when receiving CW telegraphy, to operate with selectivity at maximum.

A further increase in selectivity is obtained when the crystal filter is switched in. Moving the phasing knob away from the indicated "off" position brings the crystal into circuit. The slope of the selectivity curve (with crystal in) can be varied by movement of the phasing control to give extremely high attenuation one side or the other of the centre frequency. This feature is invaluable when interfering signals are objectionable.

AUDIO FILTER.

The highly efficient tuned audio filter will be found very useful when receiving telegraphic signals. It is tuned to approximately 1,000 cycles, has steep slopes giving a pass-band of about 100 cycles at 6 db points, and has a low insertion loss at 1,000 cycles. The switch on the front panel brings the filter into operation, the effect being to reduce drastically both background noise and interfering signals whilst leaving the desired signal clear and sharp.

RECEPTION OF TELEPHONY.

The panel controls should be set as follows :

AGC	" on."
BFO	" off."
RF Gain	maximum.
Crystal Phasing Knob			Spot against " off " position.
AF Gain	adjusted to give requisite volume.
AF Filter	" off."

For best possible audio quality, the variable selectivity control should be set at minimum. When heterodyne interference is experienced, the selectivity should be increased by moving the switch to one of the intermediate positions. A certain amount of gain compensation is automatically provided with movement of the switch. It may be mentioned that a very strong signal may overload the first stage of the receiver, necessitating a reduction of RF gain.

The tuning scales are calibrated directly in frequency to a high degree of accuracy and the flywheel controlled drive permits fine tuning on all ranges.

The mechanical bandspread device assists in the logging of particular stations. One complete revolution of the rotating scale (at the top of the dial) corresponds to a movement of the main pointer over one marked division of the lowest scale on the main dial, the length of the latter being opened out to the equivalent of 360 inches. The settings of a given station can be recorded for future use.

USE OF SIGNAL STRENGTH METER.

The Signal Strength Meter comes into operation only with the selectivity control in the maximum position, where the peaked response assists in tuning a signal accurately. The sensitive meter movement is protected by one half of a double diode valve in series with it, to prevent current flowing in the reverse direction. The RF gain should be fully advanced when using the " S " Meter.

To adjust the meter initially, the aerial and earth terminals should temporarily be shorted and the needle of the instrument made to coincide with zero by movement of the rear adjuster.

CRYSTAL CALIBRATOR.

A crystal calibrator is fitted and gives check points (oscillator beats) 500 kc/s apart, audible over the entire frequency range. The accuracy of the oscillator has been checked during factory alignment but a small trimmer is provided for adjustment, should this be found necessary at any time.

The calibrator is brought into use by pressing the switch on the front panel, and a check can then be made against any calibration mark which is an exact multiple of 500 kc/s. Incoming signals are muted to avoid confusion.

Any error in calibration is corrected by rotation of the small knurled knob on the right hand side above the dial, until the hair-line on the cursor agrees exactly with the appropriate mark on the scale.

AUDIO INPUT TERMINALS.

The two terminals situated below the "L.S." terminals at the rear are useful for feeding in any external audio voltage when it is desired to use only the AF section of the receiver. The input impedance is approximately 100,000 ohms.

EDDYSTONE MODEL 730/1A RECEIVER

GENERAL SERVICING

The "730/1A" receiver operates from A.C. mains of 40/60 cycles, the consumption being approximately 80 watts. The fuse is in series with the A.C. supply and is rated at 1 ampere standard type or 750 mA Magnickel type.

Two types of lamps are fitted behind the scale. Those for general illumination are small bayonet cap types, rated at 6.5 volts 0.3 amperes. To change a lamp it is only necessary to press the sides of the holder (accessible when the lid is lifted) and pull the lamp out.

Miniature lamps are used to indicate the range selected. These are fitted to an insulating strip, which can be drawn away complete after removing the knurled nut at the top of the strip. The cabinet has to be removed for this operation.

Should the performance fall off or perhaps fail completely, it will be well in the first place to inspect the valves for the normal heater glow. Where a metal screening can is fitted to a valve, it is easily removable with a twist and a pull. The VR150/30 valve normally exhibits a violet glow.

If it becomes necessary to obtain access to the interior, the cabinet can be completely removed after withdrawal of the four large screws at the rear. A check should be made against the operating voltages given in the table and any serious discrepancy will indicate at which stage in the circuit a fault has developed.

RE-ALIGNMENT.

The tuned circuits in the "730/1A" receiver will hold their proper alignment over a long period of time and it is inadvisable to make adjustments unless the need thereof is justified. The alignment of a receiver of this type is a skilled operation and it is most unwise to judge the effect of adjustments by ear alone. It is therefore assumed test instruments are available. Essential items are:— A Signal Generator covering from 450 kc/s to 32 Mc/s, provided with internal audio modulation (30%) and with a calibrated attenuator; an Audio Output Meter, scaled in milliwatts and decibels and adjustable to match the receiver output impedance of 2.5 ohms. Trimming should be carried out with a non-metallic tool such as the Eddystone Cat. No. 122T, which is supplied with the receiver.

IF AMPLIFIER.

The alignment of a modern variable selectivity IF amplifier as in the "730/1A" requires the use of a frequency modulated signal generator ("Wobbulator") and an oscilloscope, presenting a visual display to the operator.

It is unlikely that a fault will develop in one of the IF transformers and the adjustments of these should not be disturbed unless absolutely necessary. For check purposes, however, the following information and sensitivity figures may occasionally be useful. To obviate unsoldering the grid leads to the IF valves, the figures have been taken with these wires connected and are therefore not strictly true ones. Nevertheless, they are quite adequate for comparison purposes. The intermediate frequency is 450 kc/s (± 1.5 kc/s = crystal tolerance).

The following conditions apply when taking measurements :

Wavechange Switch Range 1.
AGC, BFO, NL off.

Receiver Crystal phasing knob at "Off."
 Selectivity maximum.
 RF Gain maximum.

Signal Generator 30% Modulation.
 Direct output.

Output Meter across and matched to speaker terminals.

Input for 50 mW output (approximate) :

Between grid V6 and chassis 11 millivolts.
Between grid V5 and chassis 220 microvolts.

To measure the overall sensitivity of the IF amplifier at the signal grid of the frequency changer (V3), it will be necessary to unsolder a lead in the frequency-changer compartment of the coil box. This lead is identified in Fig. 4 by an arrow and cross. The Signal Generator leads are connected between this lead and chassis. The sensitivity at this point should be in the region of 20 microvolts.

BFO ADJUSTMENT.

With the BFO switch off, the modulated (IF) signal applied to the receiver should be tuned in accurately with the aid of the "S" Meter, selectivity remaining at maximum. The modulation is switched off, the BFO switched on, and with the pitch control condenser at half mesh, indicated by the white spot being central at the top, the core in the BFO unit (see Fig. 4) is adjusted, if found necessary, to give zero beat against the applied signal.

ALIGNMENT OF RF SECTION.

All receiver controls are left as for IF check. The dummy aerial of the signal generator is connected between aerial and earth at the rear of the coil box. It will be found helpful to connect the speaker as well as the Output Meter for the first stage of the following procedure, which is calibration. For this, a 1,000/100 kc/s crystal oscillator, with harmonics usable up to 30 Mc/s, is essential, since the desired maximum calibration error on the dial of the receiver is 0.5%. To allow for subsequent calibration adjustments against the internal oscillator, care should be taken to ensure the vernier pointer adjuster is set at the mid point of its travel.

The location of the various trimmers and cores are shown in Fig. 4. Connect the crystal oscillator in shunt with the dummy aerial, switch on the BFO with the white spot at "12 o'clock" and, using the RF gain only as volume control, check on Range 1. Should the 28 Mc/s and 14 Mc/s harmonics be appreciably off their marks when tuned to zero beat, proceed to correct the 14 Mc/s harmonic by means of the Range 1 oscillator coil CORE. The 28 Mc/s harmonic is corrected by means of the TRIMMER. With these two points accurately fixed, the remainder of the calibrations will automatically conform to the desired 0.5% accuracy. The same procedure is used on all other ranges, the two setting points on each range being as follows :

Range 1	—	28 Mc/s and 14 Mc/s.
Range 2	—	12 Mc/s and 6 Mc/s.
Range 3	—	5.6 Mc/s and 2.5 Mc/s.
Range 4	—	2.5 Mc/s and 1.2 Mc/s.
Range 5	—	1,000 kc/s and 500 kc/s.

ALIGNMENT OF RF. AND MIXER SECTIONS.

Remove the crystal oscillator leads and use only the signal generator with the attenuator set to give about 10 microvolts. Switch off BFO. Then proceed as follows :

Inject a 13.3 Mc/s modulated signal into the receiver and tune in on Range 1 for maximum deflection on the output meter, using the RF gain to keep the needle on the scale. Now proceed to adjust the CORES only of the two RF coils and the one FC coil for highest output as indicated on the output meter. Next, inject a 28 Mc/s signal and peak this by means of the three appropriate trimmers. Repeat the whole procedure until no improvement is possible. Use the same procedure on all ranges. The high and low frequency alignment points on each range are as follows :

Range	Trimmer Frequency	Core Frequency
1	28 Mc/s	13.3 Mc/s
2	12 Mc/s	6.0 Mc/s
3	5.4 Mc/s	2.6 Mc/s
4	2.3 Mc/s	1.2 Mc/s
5	1,000 kc/s	520 kc/s

Always adjust the TRIMMERS at the high frequency ends of the bands and the CORES at the low frequency ends. This hard and fast rule applies in the alignment of all the signal frequency and oscillator coils.

Sole Manufacturers : STRATTON & CO. LTD., BIRMINGHAM, 31

Cables : Stratnoid, Birmingham

CIRCUIT No. BP. 826E.

VOLTAGE VALUES.

The voltages are between the point indicated and the chassis. Set the receiver at 1,000 kc/s on Range 5 with the aerial shorted out, R.F. control set at maximum, A.F. control set at minimum. B.F.O. and Calibrator on only for D- and B- respectively. Two sets of values are given using different meters as shown.

It will be evident that the actual voltage indicated depends on the meter employed. A tolerance of plus or minus 5% should be allowed on the values given.

POINT.	WESTON (20,000 ohms/volt.)	AVO (Model 40).
A.	218	215
B.	90	85
C.	1	1
D.	218	215
E.	95	88
F.	1	1
G.	226	224
H.	100	100
J.	1	1
K.	100	92
L.	218	216
M.	96	90
N.	1	1
O.	218	216
P.	90	85
Q.	1	1
R.	14	14
S.	80	21
T.	80	32
U.	225	206
V.	4.2	1.5
W.	4	2
X.	242	246
Y.	235	241
Z.	242	246
A.-	10	9.4
B.-	25	15
C.-	160	150
D.-	85	85.
E.-	255 A.C.	252 A.C.
F.-	275	272
G.-	148	148
H.-	140	125

VALVES.

VALVE No.	TYPE	SERIES
1.	6BA6	B7G
2.	6BA6	B7G
3.	6BE6	B7G
4.	6AM6 (8D3)	B7G
5.	6BA6	B7G
6.	6BA6	B7G
7.	6AL5	B7G
8.	12AU7	B9A (Noval)
9.	6AM5 (7D9)	B7G
10.	6AM6 (8D3)	B7G
11.	6AL5	B7G
12.	6BA6	B7G
13.	5Z4G	Octal
14.	VR150/30	Octal

CIRCUIT No. BP. 826E.

COMPONENT VALUES.

CAPACITORS

C1.	3-23 pF Air Trimmer	C60.	500 pF Silvered Mica $\pm 2\%$
C2.	10 pF Silvered Mica	C61.	.1 mfd Tub. paper
C3.	3-23 pF Air Trimmer	C62.	.1 mfd Tub. paper
C4.	3-23 pF Air Trimmer	C63.	400 pF Silvered Mica $\pm 2\%$
C5.	3-23 pF Air Trimmer	C64.	400 pF Silvered Mica $\pm 2\%$
C6.	3-23 pF Air Trimmer	C65.	.01 mfd Tub. paper
C7.	100 pF Silvered Mica	C66.	.1 mfd Tub. paper
C8.	.0005 mfd Moulded Mica	C67.	.1 mfd Tub. paper
C9.	10-367.75 pF 1st R.F. Sect. 4 Gang	C68.	400 pF Silvered Mica $\pm 2\%$
C10.	25 pF Silvered Mica	C69.	400 pF Silvered Mica $\pm 2\%$
C11.	.01 mfd Tub. paper	C70.	20 pF Silvered Mica
C12.	.01 mfd Tub. paper	C71.	.1 mfd Tub. paper
C13.	.1 mfd Tub. paper	C72.	100 pF Silvered Mica
C14.	.0005 mfd Moulded Mica	C73.	100 pF Silvered Mica
C15.	.1 mfd Tub. paper	C74.	.1 mfd Tub. paper
C16.	.1 mfd Tub. paper	C75.	.1 mfd Tub. paper
C17.	20 pF Silvered Mica	C76.	.01 mfd Tub. paper
C18.	3-23 pF Air Trimmer	C77.	30 mfd Tub. Elect. 15V. D.C. Wkg.
C19.	6 pF Silvered Mica	C78.	8 mfd Tub. Elect.
C20.	3-23 pF Air Trimmer	C79.	.01 mfd Moulded Mica
C21.	3 pF Silvered Mica	C80.	.01 mfd Moulded Mica
C22.	3-23 pF Air Trimmer	C81.	7,000 pF Silvered Mica $\pm 1\%$
C23.	3 pF Silvered Mica	C82.	7,000 pF Silvered Mica $\pm 1\%$
C24.	3-23 pF Air Trimmer	C83.	30 mfd Tub. Elect. 15V. D.C. Wkg.
C25.	3-23 pF Air Trimmer	C84.	.01 mfd Moulded Mica
C26.	10-367.75 pF 2nd. R.F. Sect. 4 Gang	C85.	3-23 pF Air Trimmer
C27.	25 pF Silvered Mica	C86.	20 pF Silvered Mica
C29.	.1 mfd Tub. paper	C87.	.01 mfd Moulded Mica
C30.	.01 mfd Tub. paper	C88.	7,000 pF Silvered Mica $\pm 1\%$
C31.	100 pF Silvered Mica	C89.	3-23 pF Air Trimmer
C32.	.1 mfd Tub. paper	C90.	3-23 pF Air Trimmer
C33.	.1 mfd Tub. paper	C91.	3,625 pF Silvered Mica $\pm 1\%$
C34.	20 pF Silvered Mica	C92.	1,625 pF Silvered Mica $\pm 1\%$
C35.	3-23 pF Air Trimmer	C93.	10 pF Silvered Mica
C36.	20 pF Silvered Mica	C94.	3-23 pF Air Trimmer
C37.	6 pF Silvered Mica	C95.	900 pF Silvered Mica $\pm 1\%$
C38.	3-23 pF Air Trimmer	C96.	20 pF Silvered Mica $\pm 1\%$
C39.	3 pF Silvered Mica	C97.	3-23 pF Air Trimmer
C40.	3-23 pF Air Trimmer	C98.	440 pF Silvered Mica $\pm 1\%$
C41.	3 pF Silvered Mica	C99.	20 pF Silvered Mica $\pm 1\%$
C42.	3-23 pF Air Trimmer	C100.	3-23 pF Air Trimmer
C43.	3-23 pF Air Trimmer	C101.	200 pF Ceramic
C44.	.1 mfd Tub. paper	C102.	10-367.75 pF Osc. Sect. 4 Gang
C45.	400 pF Silvered Mica $\pm 2\%$	C103.	12 pF Ceramic
C46.	800 pF Silvered Mica $\pm 2\%$	C104.	.1 mfd Tub. paper
C47.	800 pF Silvered Mica $\pm 2\%$	C105.	.0005 mfd Moulded Mica
C48.	Crystal Phasing Cond.	C106.	.0005 mfd Moulded Mica
C50.	10-367.75 pF Frq. change sect. 4 Gang	C107.	50 pF Ceramic
C51.	25 pF Silvered Mica	C108.	.002 mfd Moulded Mica
C52.	.01 mfd Tub. paper	C109.	.01 mfd Moulded Mica
C53.	.01 mfd Tub. paper	C110.	8 pF Silvered Mica
C54.	.1 mfd Tub. paper	C111.	100 pF Silvered Mica
C55.	.1 mfd Tub. paper	C112.	B.F.O. Pitch Cond.
C56.	10 pF Ceramic	C113.	100 pF Silvered Mica
C57.	.01 mfd Tub. paper	C114.	.01 mfd Tub. paper
C58.	.01 mfd Moulded Mica	C115.	.01 mfd Tub. paper
C59.	20 pF Silvered Mica	C116.	.01 mfd Tub. paper
		C117.	16 mfd Tub. Elect. 450V. D.C. Wkg.
		C118.	40 mfd Tub. Elect. 350V. D.C. Wkg.
		C119.	.01 mfd Tub. paper

RESISTORS.

R1.	12 ohms	
R2.	.47 Megohm	
R3.	.47 Megohm	
R4.	68 ohms	
R5.	33,000 ohms.	1W
R6.	1,000 ohms	
R7.	150 ohms	
R8.	12 ohms	
R9.	.47 Megohm	
R11.	68 ohms	
R12.	33,000 ohms.	1W
R13.	1,000 ohms	
R14.	1,000 ohms	
R15.	150 ohms	
R16.	1,000 ohms	
R17.	12 ohms	
R19.	.1 Megohm	
R20.	.47 Megohm	
R21.	150 ohms	
R22.	.47 Megohm	
R23.	15,000 ohms	
R24.	1,000 ohms	
R25.	33,000 ohms.	1W
R26.	1,000 ohms	
R27.	15,000 ohms	
R28.	.47 Megohm	
R29.	820 ohms	
R30.	3,300 ohms	
R31.	1,200 ohms	
R32.	68 ohms	
R33.	1 Megohm	
R34.	68 ohms	
R35.	.1 Megohm	
R36.	.1 Megohm	
R37.	10,000 ohms	
R38.	.22 Megohm	
R39.	.1 Megohm	
R40.	.5 Megohm.	Potentiometer
R41.	1 Megohm	
R42.	.47 Megohm	
R43.	6,800 ohms	
R44.	2,200 ohms	
R45.	1 Megohm	
R46.	1 Megohm	
R47.	.47 Megohm	
R48.	680 ohms	
R49.	47,000 ohms	
R50.	4,700 ohms	
R51.	1 Megohm	
R52.	.1 Megohm	
R53.	22,000 ohms	
R54.	2,200 ohms	
R55.	2,200 ohms	
R56.	10,000 ohms	
R57.	1,000 ohms	
R58.	22,000 ohms	
R59.	10,000 ohms	
R60.	5,000 ohms.	Potentiometer
R61.	27,000 ohms.	1W
R62.	2 Megohm	
R63.	47,000 ohms	
R64.	10,000 ohms	
R65.	10,000 ohms.	Potentiometer
R66.	2,700 ohms.	Wire Wound
R67.	4,700 ohms	
R68.	22,000 ohms.	1W
R69.	.27 Megohm	
R70.	5 ohms.	Potentiometer
R71.	6,800 ohms	
R72.	.1 Megohm	
R73.	6,800 ohms	
R74.	100,000 ohms	
R75.	47 ohms	
R76.	3 Megohms	
R18	12 ohms	

EDDYSTONE RECEIVER MODEL 730/1A

PERFORMANCE FIGURES

SENSITIVITY

For signal-to-noise ratio of 15 db, output power 50 milliwatts :

A.M. signal, modulated 30% at 400 cycles	better than 5 μ V
C.W. signal, ranges 1, 2, 3, 4	better than 1 μ V
C.W. signal, range 5	better than 2 μ V

AUDIO OUTPUT AND HARMONIC DISTORTION.

At 1,000 cycles, output impedance 2.5 ohms

	Typical performance	Production limit
1 watt	18%	20%
500 milliwatts	6.2%	7%
100 milliwatts	2.5%	3%

AUTOMATIC GAIN CONTROL.

Typical performance figures taken at 8 Mc/s. :

Selectivity position	Change of input	Change of output	Zero level
Narrow	100db	6db	1 μ V
Inter 1	100db	8db	3 μ V
Inter 2	100db	12db	3 μ V
Wide	100db	11db	3 μ V

Figures taken at 750 kc/s.

Narrow	100db	7db	1 μ V
Inter 1	100db	8db	3 μ V
Inter 2	100db	10db	3 μ V
Wide	100db	10db	3 μ V

Production limits :— at any frequency and any bandwidth, a 100db change of input will not change the output power by more than 14db (zero level 3 μ V).

OSCILLATOR STABILITY (Production limits)

BFO note stability with AGC — for an input change of 60db from a level of 10db above 1 μ V, the beat note does not change by more than 50 cycles.

BFO thermal stability — after a 30 minute warming-up period, the total drift in one hour does not exceed 225 parts in one million.

BFO voltage co-efficient — for a $\pm 10\%$ change in supply voltage, the frequency of the BFO does not change by more than ± 80 cycles (equal to 3.4 cycles per volt).

Local oscillator thermal stability — after two hours warm-up, the total drift does not exceed 150 parts in one million over a period of one hour, under steady ambient temperature conditions and with stable mains supply.

Local oscillator voltage co-efficient — for a $\pm 10\%$ change in supply voltage, the frequency of the local oscillator does not change by more than the following :—

at 2.4 Mc/s.	± 200 cycles (4.2 cycles per volt)
at 20 Mc/s.	± 2 kilocycles (86 cycles per volt).

NOISE FACTOR.

750 kc/s.	12db	}	noise measurements at these frequencies not normally reliable.
2 Mc/s.	5db		
4 Mc/s.	10.5db	}	± 3 db
9 Mc/s.	6.5db		
20 Mc/s.	9.5db		

CURSOR ADJUSTER

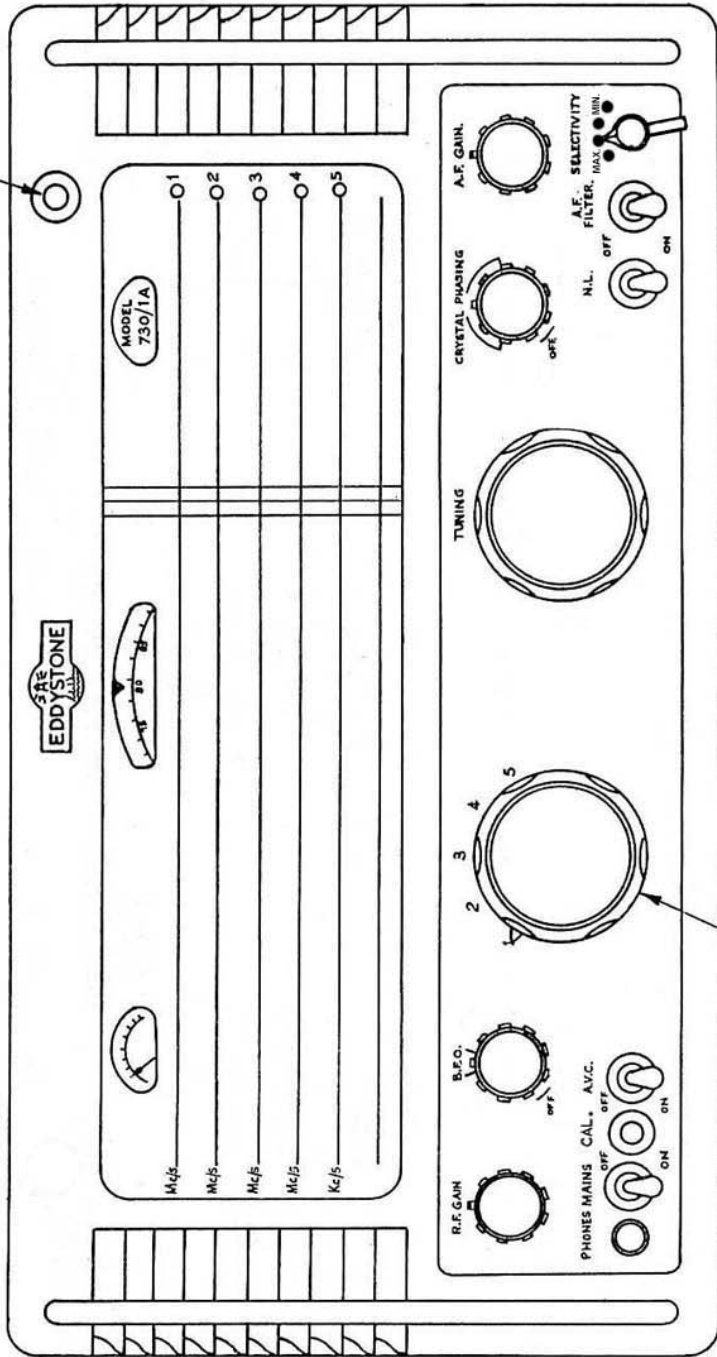

WAVECHANGE.

Fig. 1. Front view, in outline, of the "730/1A" Receiver

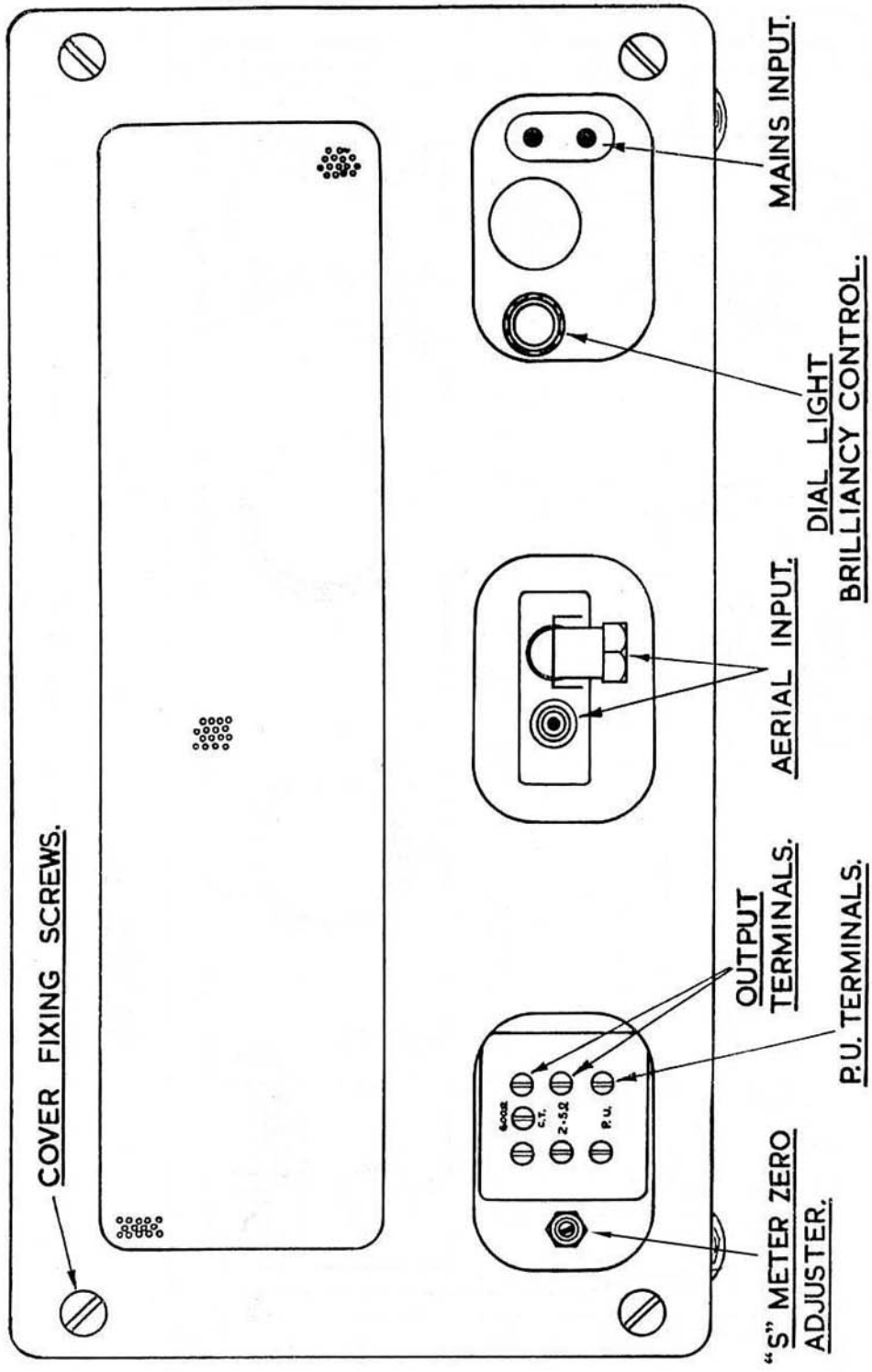

Fig. 2. Rear view of the "730/1A" Receiver, in outline

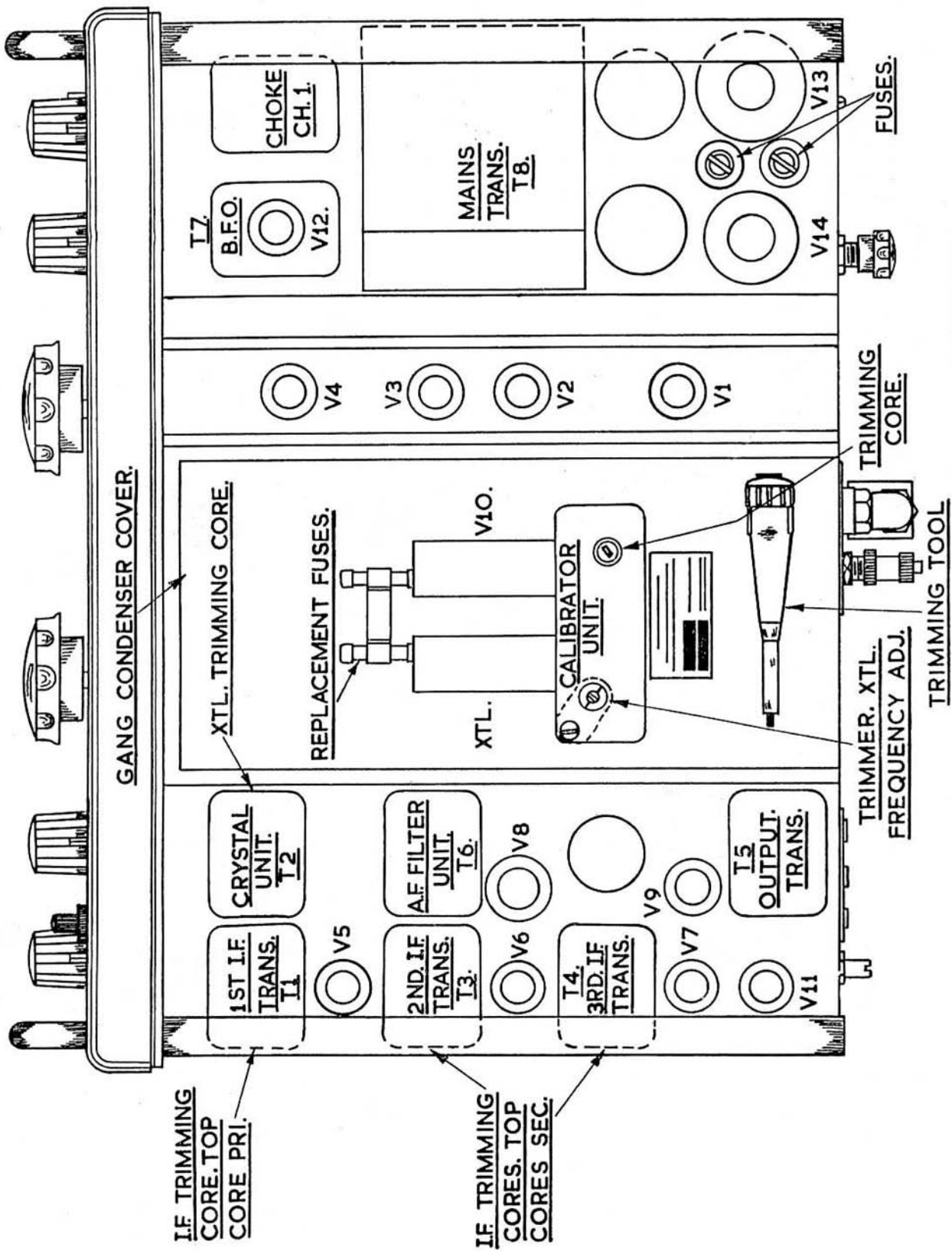

Fig. 3. Plan view of the "730/1A" Receiver, in outline

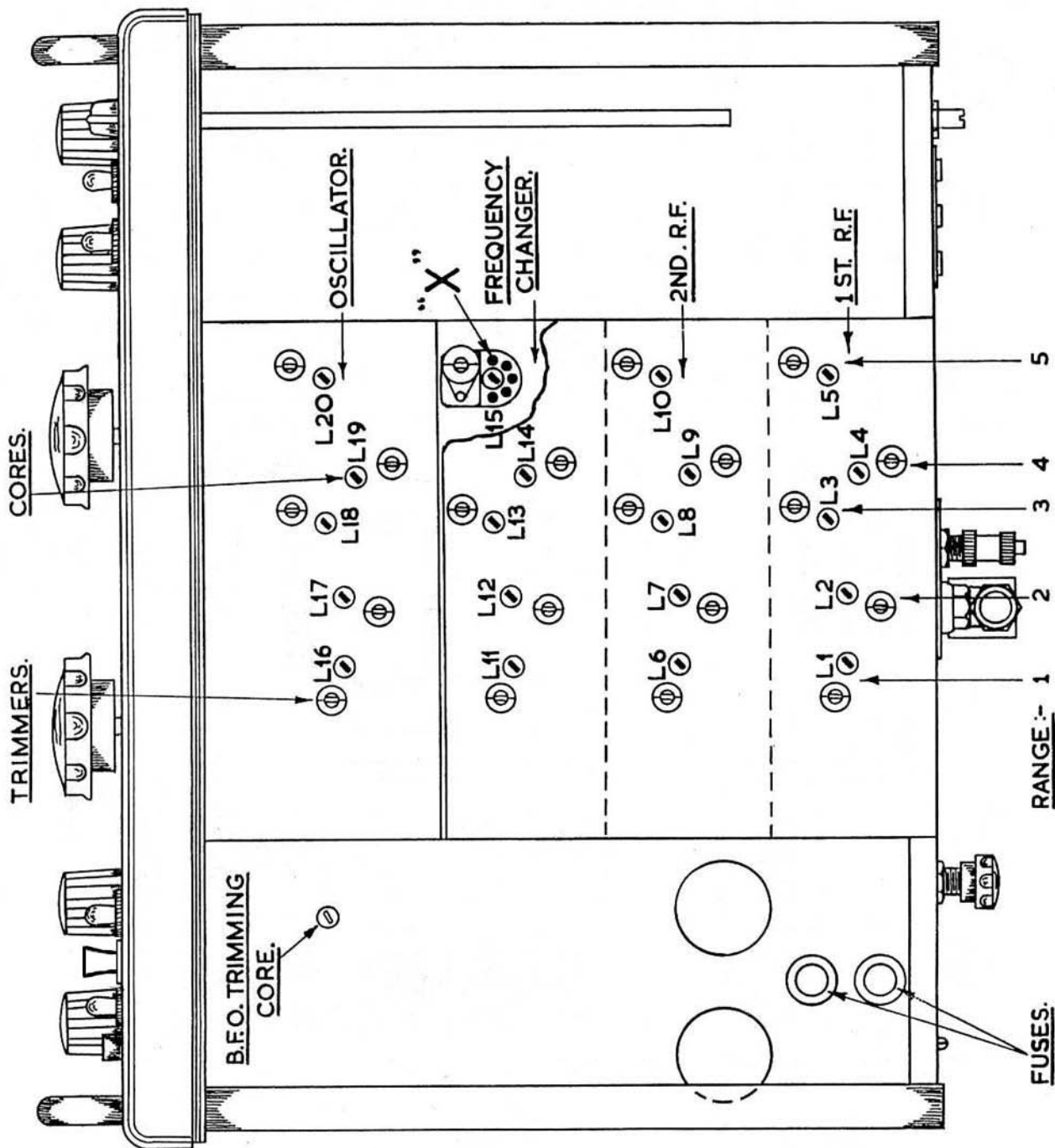
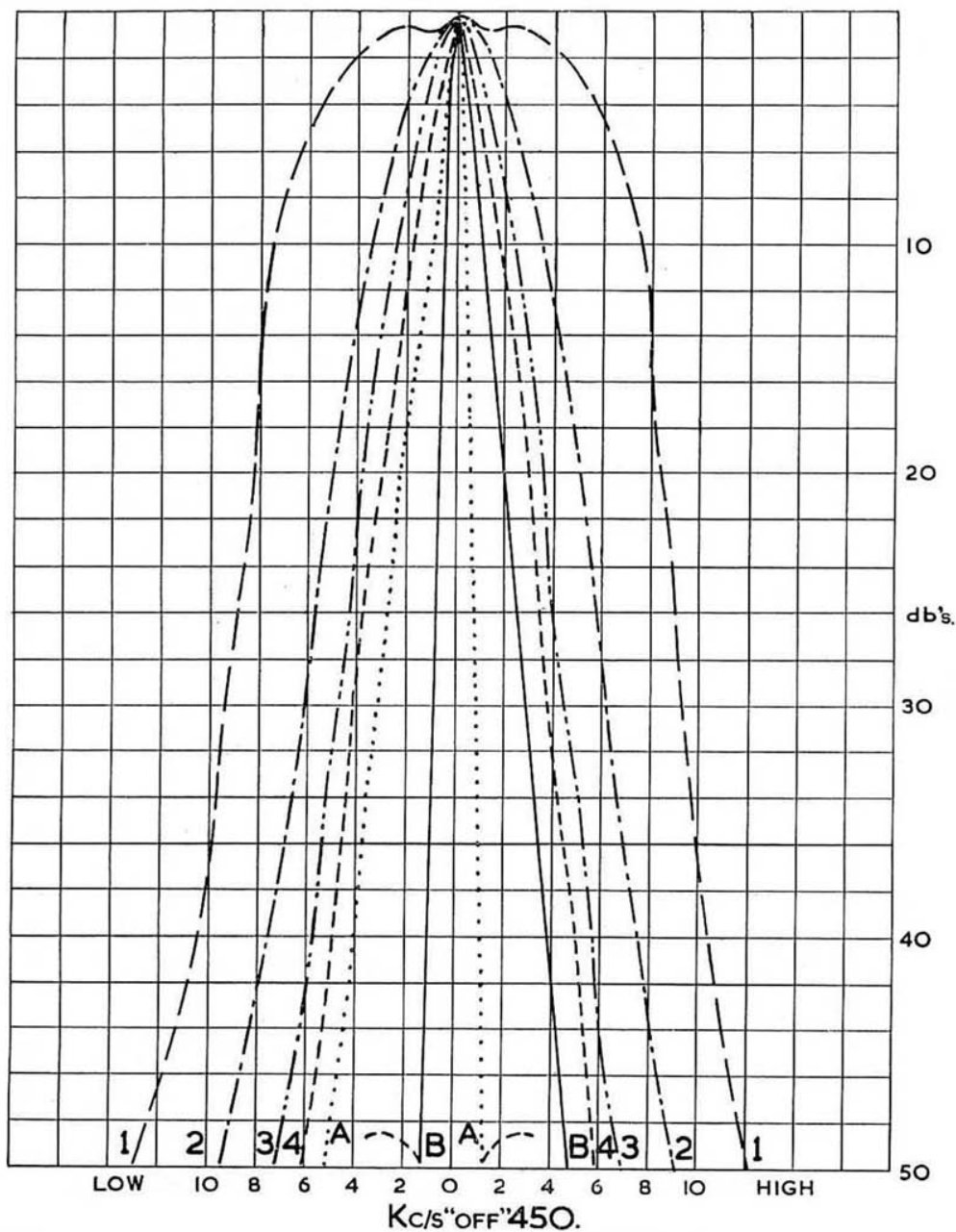

Fig. 4. Underside view, in outline, of the "730/1A" Receiver

Fig. 5. Average selectivity curves of the "730/1A" Receiver



- | | |
|------------|--|
| (1) ———— | MINIMUM POSITION. |
| (2) ———— | FIRST INTERMEDIATE POSITION. |
| (3) ———— | SECOND INTERMEDIATE POSITION. |
| (4) ———— | MAXIMUM SELECTIVITY. |
| (A) ······ | MAXIMUM SELECTIVITY WITH CRYSTAL
FILTER IN, & PHASED TO REJECT
SIGNAL ON ONE SIDE. |
| (B) ———— | AS A BUT WITH CRYSTAL PHASED ON
OTHER SIDE |

A.F. FILTER UNIT.
RESPONSE CURVE.

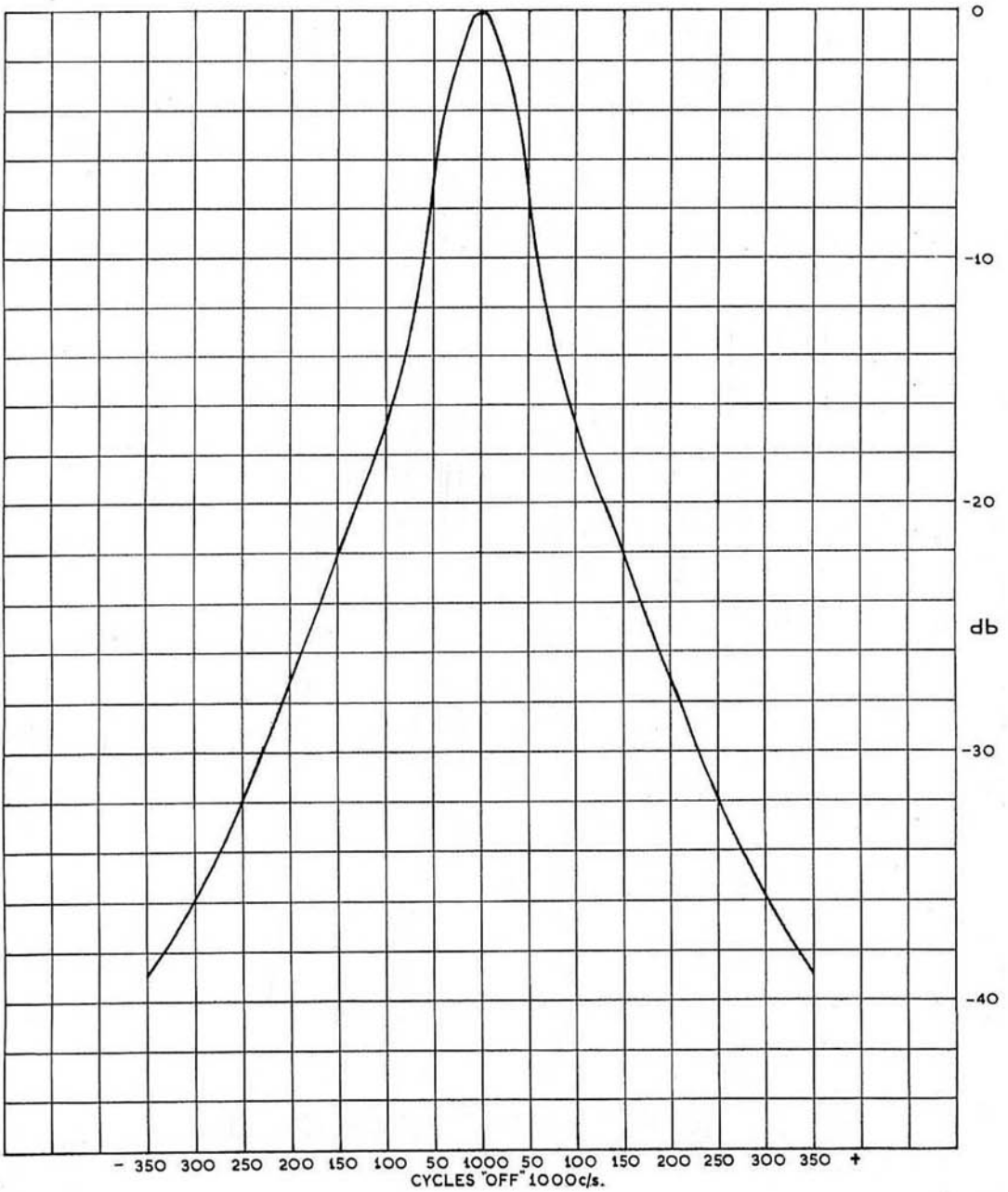

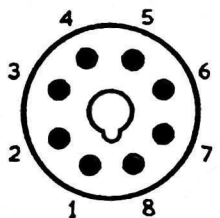
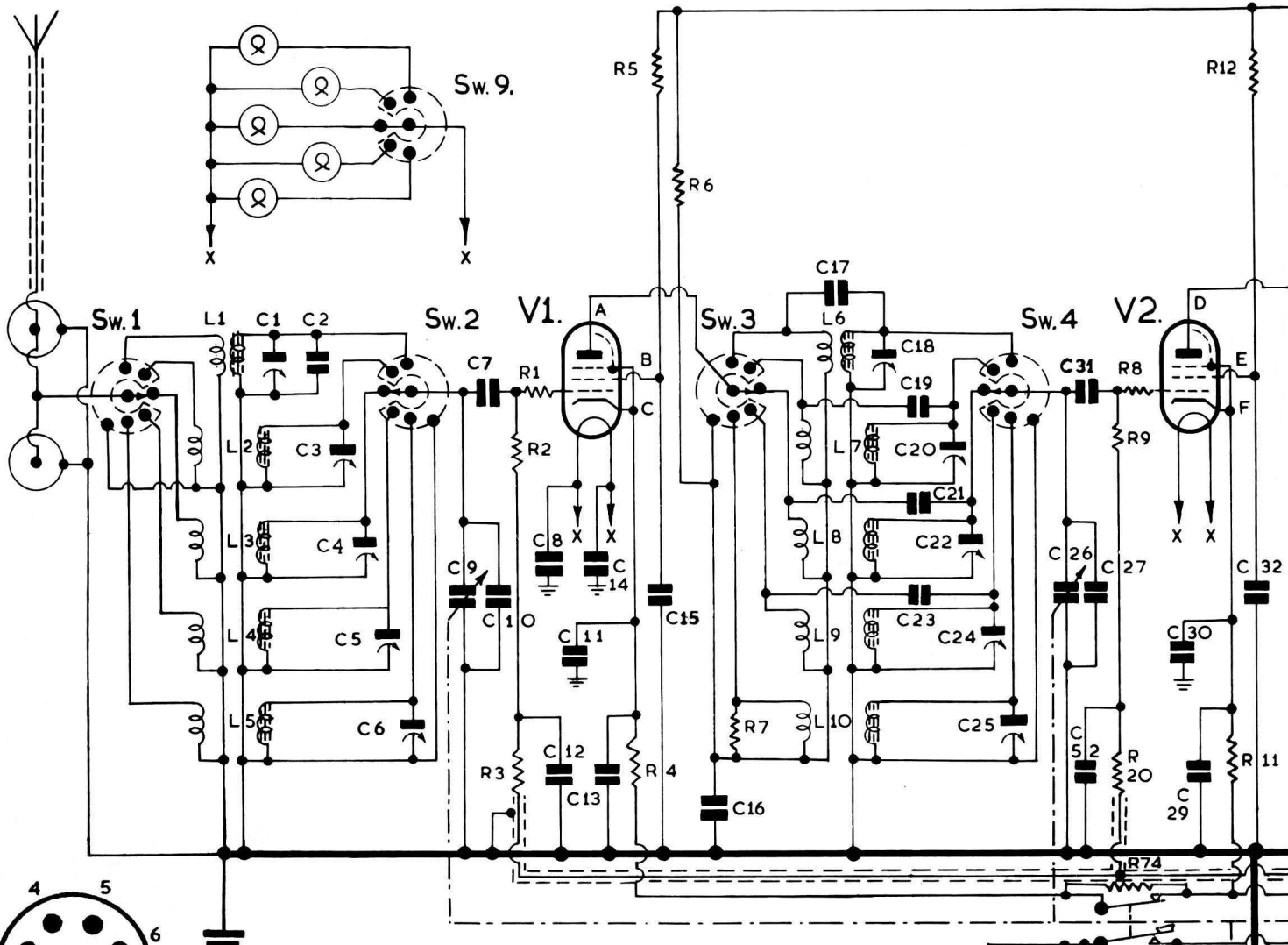

OCTAL SERIES.

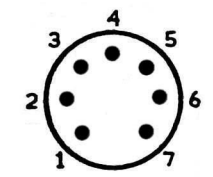

B7G SERIES.

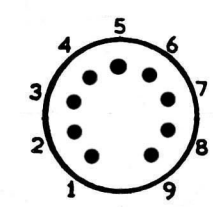

B9A SERIES.

VALVE	V.No.	PIN CONNECTIONS.									SERIES	SERVICE NUMBERS
		1	2	3	4	5	6	7	8	9		
6BA6	V1,2,5, 6 & 12	G1	G3	H	H	A	G2	K	-	-	B7G	CV 454.
6BE6	V3	G1	K	H	H	A	G2	G3	-	-	B7G	CV 453.
12AU7	V8	A2	G2	K2	H	H	A1	G1	K1	H TAP	B9A (NOVAL)	CV 491.
8D3 (6AM6)	V4 & 10	G1	K	H	H	A	G3	G2	-	-	B7G	CV 138.
7D9 (6AM5)	V9	G1	K	H	H	A	-	G2	-	-	B7G	CV 136.
5Z4G	V13	-	H	-	A2	-	A1	-	K	-	OCTAL	CV 1863
VR150/30	V14	-	K	-	-	A	-	-	-	-	OCTAL	CV 216
6AL5	V7 & 11	K1	A2	H	H	K2	S	A1	-	-	B7G.	CV 140.
XTL.A.	-	G1	G1	G1	-	E	E	E	-	-	B7G.	

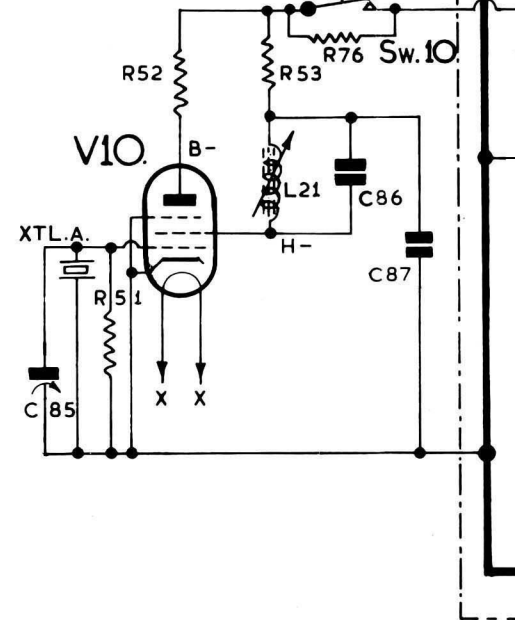

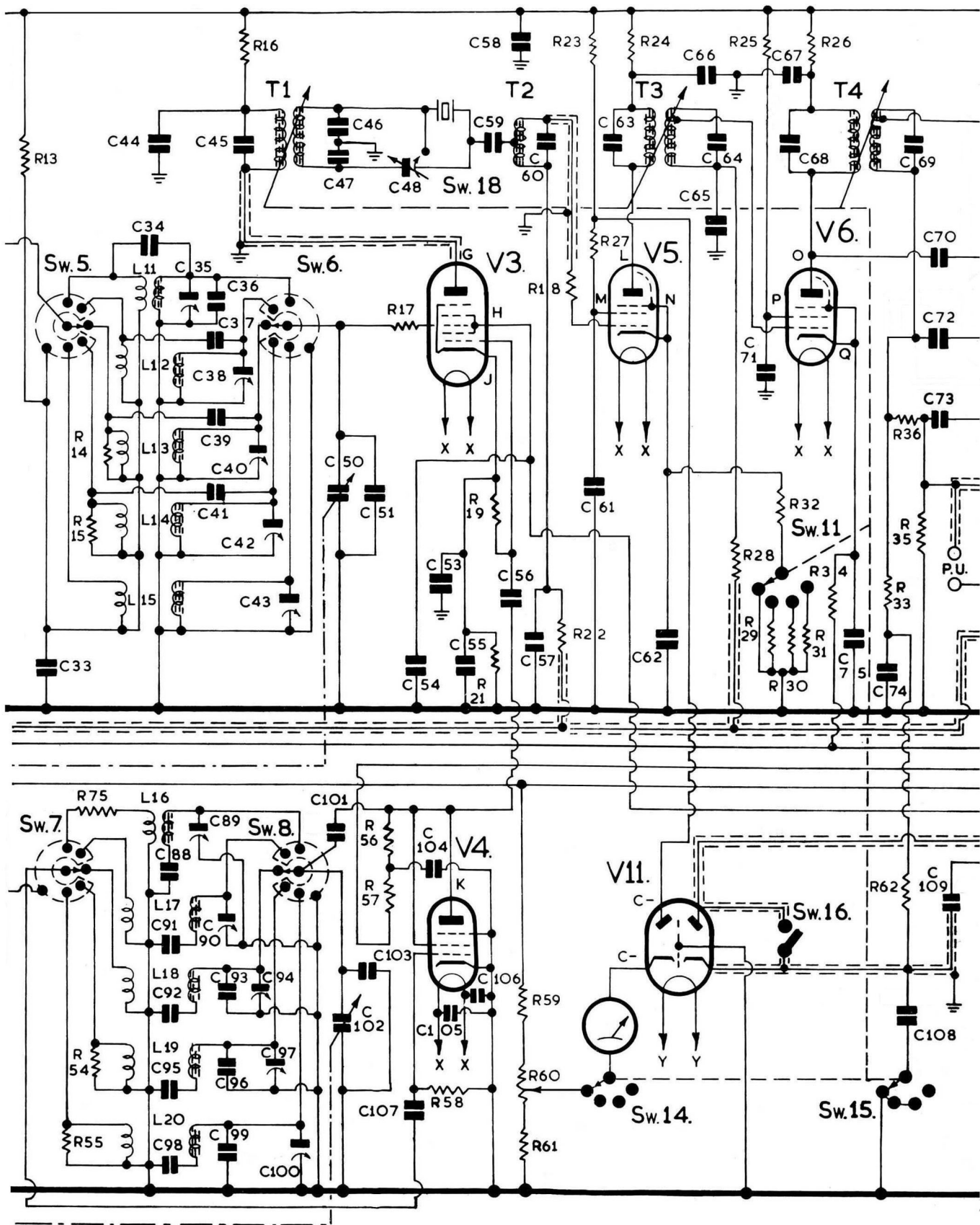

NS RECEIVER TYPE 730/1A & 730

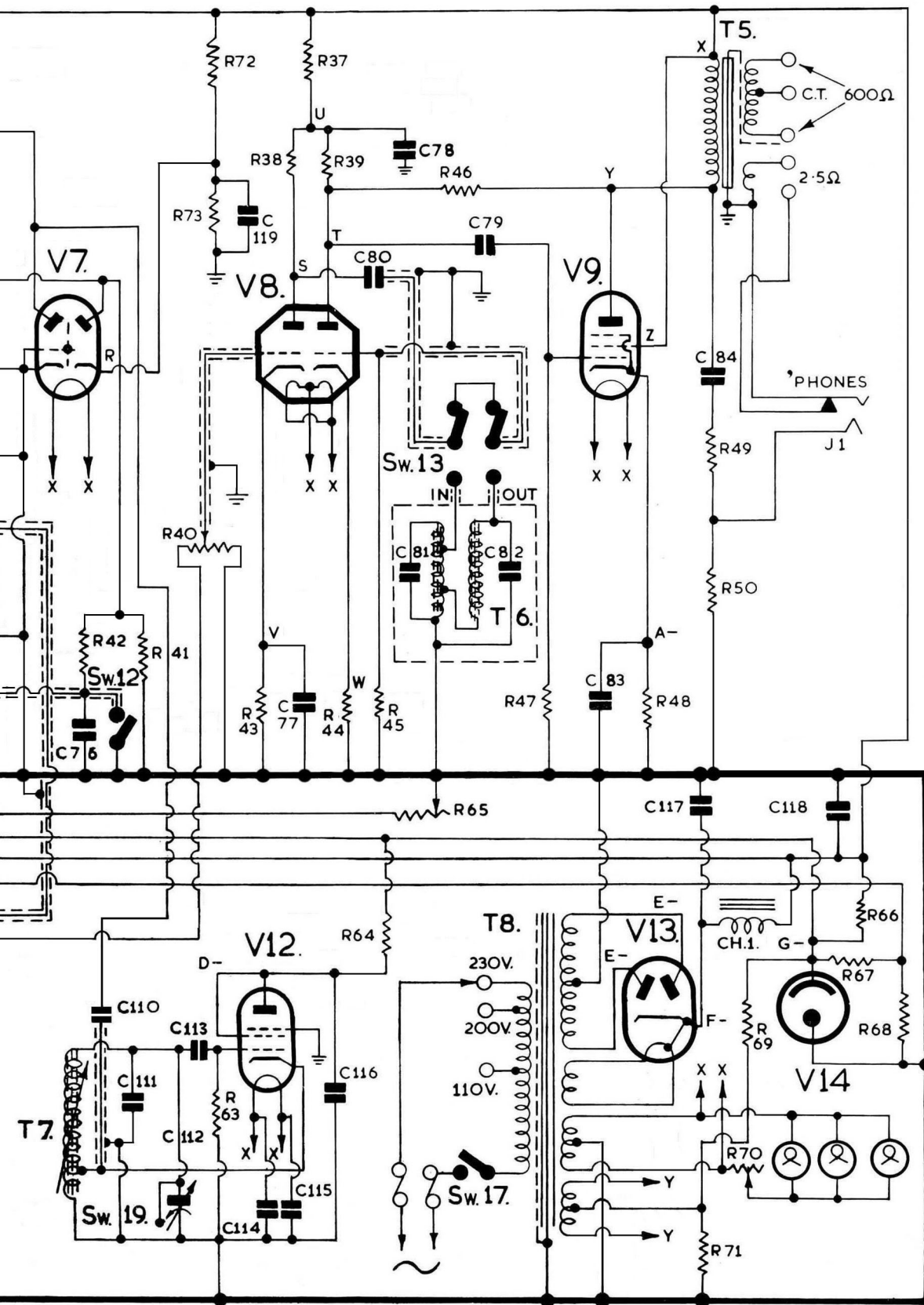

REVISIONS

- A. SCREENING FROM GRIDS OF V8 & FROM C80 ADDED W.J.S. 3-12-53
- B. HEATER OF V8 WAS TO EARTH W.J.S. 3-9-54
- C. R10 & C28 DELETED R74 ADDED. WAS TYPE 730/1 W.J.S. 28-9-54
- D. R75 ADDED W.J.S. 2-1-55
- E. R76 ADDED W.J.S. 1-6-55.
- F. R18 & C49 DELETED R.S.S. 20-9-55.
- G. R18 & SCREEN LEADS ADDED. R.S.S. 20-10-55

S730/1A	
STRATTON & CO LTD BIRMINGHAM ENGLAND	
DRAWING No BP826	
DRAWN	W.J.S.
TRACED	R.S.S. 29-8-55
CHECKED	T.M. 21-2-07
APPROVED	
DATE	22-9-53

1/2 (MINUS CO-AX INPUT.)

BP826.